



ECS0107

**FITTING INSTRUCTIONS FOR ECS0107BK ENGINE CASE SLIDERS**  
**SUZUKI SV650 A 2016- (RIGHT HAND SIDE ONLY)**



**Please note that the way the kit is packed does not necessarily represent the way of mounting to the bike**

Please note that in cases where kits are packed with rubber washers holding the components onto the bolt – *the rubber washers should be thrown away!*

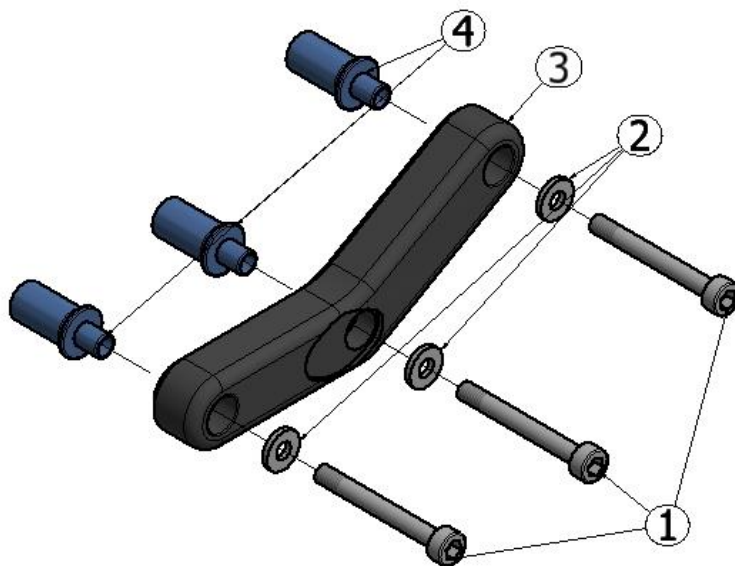

R&G Racing

Unit 1, Shelley's Lane, East Worldham, Alton, Hampshire, GU34 3AQ

Tel: +44 (0)1420 89007 Fax: +44 (0)1420 87301 [www.rg-racing.com](http://www.rg-racing.com) Email: [info@rg-racing.com](mailto:info@rg-racing.com)



ECS0107

**Tools Required**

- 8mm socket and a wrench
- 6mm Allen key
- Torque wrench

**Legend**

Item 1= M6 Bolts (x3)

Item 2= M6 Washers (x3)

Item 3= R&G Slider (ECS0106BK) (x1)

Item 4= Compression sleeves (CS492) (x3)

**Left-hand side (as you sit on bike)**

- Remove the three OEM M6 bolts as positioned (arrowed) above using an 8mm socket and a wrench.
- Insert new cap head bolts with washers through the slider and the compression sleeves as illustrated above.
- Offer the assembly to the LHS engine case.
- Tighten evenly to manufactures specified torque.
- Fit bubble sticker as shown above.

**GENERAL TORQUE SETTINGS**

M4 BOLT = 8Nm

M5 BOLT = 12Nm

M6 BOLT = 15Nm

M8 BOLT = 20Nm

M10 BOLT = 40Nm

Issue 1 25/07/2016 (HH)

**CONSUMER NOTICE**

The catalogue description and any exhibition of samples are only broad indications of the Products and R&G may make design changes which do not diminish their performance or visual appeal and supplying them in such state shall conform to the order. The Buyer acknowledges no representation or warranty (other than as to title) has been given or will apply to the Products other than those in R&G's order or confirmation and the Buyer confirms it has chosen the Products as being of merchantable quality and suitable for its particular purposes. Where R&G fits the Products or undertakes other services it shall exercise reasonable skill and care and rectify any fault free of charge unless the workmanship has been disturbed. The Buyer is responsible for ensuring that the warranty on the motorcycle is not affected by the fitting of the Products. On return of any defective Products R&G shall at its option either supply a replacement or refund the purchase money but shall not be liable if the Products have been modified or used or maintained otherwise than in accordance with R&G's or manufacturer's instructions and good engineering practice or if the defect arises from accident or neglect. Other than identified above and subject to R&G not limiting its liability for causing death and personal injury, it shall not be liable for indirect or consequential loss and otherwise its liability shall be limited to the amounts paid by the Buyer for the Products or the fitting or service concerned. These terms do not affect the Buyer's statutory rights.

**R&G RACING RETURNS POLICY (NON-FAULTY GOODS)**

Returns must be pre-authorized (if not pre-authorized the return will be rejected). Goods may only be returned direct to us if they were purchased direct from us (customer must prove if necessary). Otherwise to be returned to original vendor. Goods must be in resellable condition, in the opinion of R&G Racing. All returns are subject to a 25% restocking and handling fee (25% of the gross value exc. P&P – at the prevailing price at time of purchase). The customer must pay any and all carriage charges. No returns of discontinued products, unless within 14 days of purchase. This policy does not affect your statutory rights and does not refer to faulty goods.

R&G Racing

Unit 1, Shelley's Lane, East Worldham, Alton, Hampshire, GU34 3AQ

Tel: +44 (0)1420 89007 Fax: +44 (0)1420 87301 [www.rg-racing.com](http://www.rg-racing.com) Email: [info@rg-racing.com](mailto:info@rg-racing.com)



ECS0107

**NOTICE DE MONTAGE POUR ECS0107BK PROTECTIONS CRASH  
SUZUKI SV650 A 2016- (COTE DROIT UNIQUEMENT)**



La façon dont le kit est emballé ne correspond pas forcément à la façon de monter les pièces sur la moto.

**NOTEZ QUE SI LES KITS SONT EMBALLES AVEC DES RONDELLES EN CAOUTCHOUC SERVANT A TENIR LES COMPOSANTS,  
CES RONDELLES DOIVENT ETRE JETTES!**

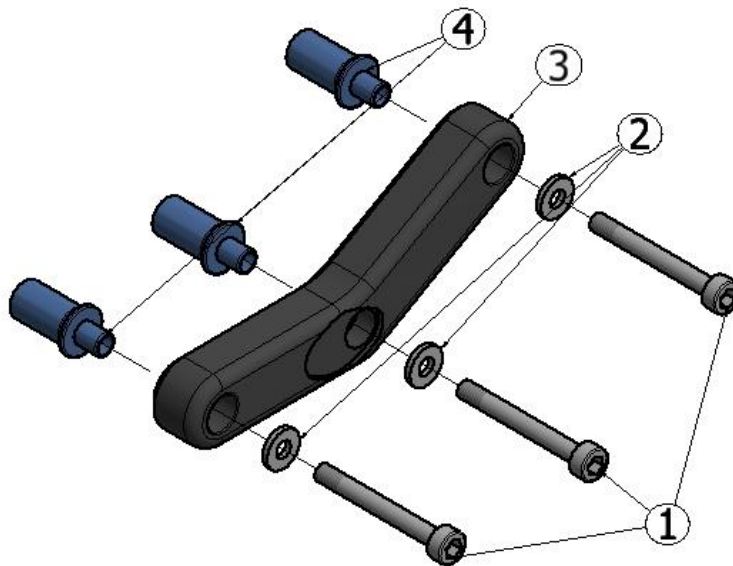



ECS0107

**OUTILS REQUIS**

- Clé et douilles 8mm
- Clé Allen 6mm
- Clé dynamométrique

**LEGENDE :**

Article 1= M6 Boulons (x3)

Article 2= M6 Rondelles (x3)

Article 3= R&G Slider (ECS0107BK) (x1)

Article 4= Manchons de compression (CS492) (x3)

**Coté gauche (assis sur la moto)**

- Enlever 3 boulons M6 comme indiqué ci-dessus, en utilisant une clé à douille 8mm.
- Insérer les nouveaux boulons avec rondelles dans le slider et manchons de compression, comme illustré ci-dessus.
- Monter l'ensemble sur le carter moteur du coté droit.
- Serrer selon recommandations.
- Insérer les stickers en caoutchouc, voir ci-dessus.

**COUPLES DE SERRAGE RECOMMANDES:**

M4 BOULON = 8Nm  
M5 BOULON = 12Nm  
M6 BOULON = 15Nm  
M8 BOULON = 20Nm  
M10 BOULON = 40Nm

Issue 1 25/07/2016 (HH)

**CONSUMER NOTICE**

The catalogue description and any exhibition of samples are only broad indications of the Products and R&G may make design changes which do not diminish their performance or visual appeal and supplying them in such state shall conform to the order. The Buyer acknowledges no representation or warranty (other than as to title) has been given or will apply to the Products other than those in R&G's order or confirmation and the Buyer confirms it has chosen the Products as being of merchantable quality and suitable for its particular purposes. Where R&G fits the Products or undertakes other services it shall exercise reasonable skill and care and rectify any fault free of charge unless the workmanship has been disturbed. The Buyer is responsible for ensuring that the warranty on the motorcycle is not affected by the fitting of the Products. On return of any defective Products R&G shall at its option either supply a replacement or refund the purchase money but shall not be liable if the Products have been modified or used or maintained otherwise than in accordance with R&G's or manufacturer's instructions and good engineering practice or if the defect arises from accident or neglect. Other than identified above and subject to R&G not limiting its liability for causing death and personal injury, it shall not be liable for indirect or consequential loss and otherwise its liability shall be limited to the amounts paid by the Buyer for the Products or the fitting or service concerned. These terms do not affect the Buyer's statutory rights.

**R&G RACING RETURNS POLICY (NON-FAULTY GOODS)**

Returns must be pre-authorized (if not pre-authorized the return will be rejected). Goods may only be returned direct to us if they were purchased direct from us (customer must prove if necessary). Otherwise to be returned to original vendor. Goods must be in resellable condition, in the opinion of R&G Racing. All returns are subject to a 25% restocking and handling fee (25% of the gross value exc. P&P – at the prevailing price at time of purchase). The customer must pay any and all carriage charges. No returns of discontinued products, unless within 14 days of purchase. This policy does not affect your statutory rights and does not refer to faulty goods.

R&G Racing

Unit 1, Shelley's Lane, East Worldham, Alton, Hampshire, GU34 3AQ

Tel: +44 (0)1420 89007 Fax: +44 (0)1420 87301 [www.rg-racing.com](http://www.rg-racing.com) Email: [info@rg-racing.com](mailto:info@rg-racing.com)